



VIGIA-VL

HIGH PROCESSING, CONNECTIVITY AND EMBEDDED SOFTWARE

| Product

Pumatronix Equipamentos Eletrônicos Ltda.

Rua Bartolomeu Lourenço de Gusmão, 1970. Curitiba, Brasil

Copyright 2020 Pumatronix Equipamentos Eletrônicos Ltda.

All rights reserved.

Visit our website <https://www.pumatronix.com>

Please send feedback on this document to suporte@pumatronix.com

Information contained in this document is subject to change without notice.

Pumatronix reserves the right to modify or improve this material without obligation to notify you of changes or improvements.

Pumatronix grants permission to download and print this document, provided that the electronic or physical copy of this document contains the entire text. Any alteration to this content is strictly prohibited.

Change History

Date	Revision	Content updated
31/03/2023	1.0	Initial Version
05/07/2023	1.1	Operating temperature update
04/15/2024	1.2	Operating Temperature Update
06/03/2024	1.3.0	Inclusion of the New Controller Module; Image update; Update of chapter layout
02/17/2025	1.4.0	Update of Electrical Specifications; Update of the indication of the interfaces of the New Controller Module; (SAD-719)

Overview

The continuous increase of the population in urban areas implies great challenges in the public management of cities. Intelligent services that use Information and Communication Technologies (ICTs) are becoming increasingly relevant in helping to monitor, control, and make quick decisions to solve problems inherent to the large concentration of people, such as mobility and traffic safety, energy efficiency, public safety, and supply control, among others.

The concept called (*Smart Cities*) is a global trend that classifies the strategic use of infrastructure and services from the application of ICT solutions in urban planning and management, bringing results to the social and economic needs of society. Thus, the use of Information Technology allows cities to develop economically while improving the quality of life of their inhabitants by generating efficiency in urban operations.

Examples of these technologies are Intelligent Traffic Systems (Intelligent Traffic Systems - ITS), in which Pumatronix products, such as VIGIA-VL, are used. This system helps to reduce traffic congestion, which contributes to minimizing vehicle emissions. Likewise, it increases safety by detecting the presence of vehicles through the use of *Laço Virtual (Virtual Loop)* regions for the track, which can be tracked in real time. The image processing system for traffic monitoring VIGIA-VL performs:

- Detecting the presence of vehicles in images, using virtual loops;
- Classification of the vehicles detected in the virtual loops, with typical classification values above 80% (provided that the installation requirements are met);
- Vehicle count for each monitored lane, with typical count values above 90% (as long as the installation requirements are met);
- Collecting statistical traffic data;
- Interconnection with several brands of Semaphore Controllers.

Handling Risks



Artificial Lighting: For the accuracy of the data generated by the VIGIA-VL system, the existing public lighting should favor the detection of vehicles when capturing images at night and in adverse weather conditions, such as fog, rain, and the like.



Be careful when installing the VIGIA-VLIO Controller Module: As it has no protection against dust and water penetration, this module cannot be exposed to weather outdoors and must be installed in a sheltered place.



Power Supply to the VIGIA-VLIO Controller Module: To power the module with a voltage of 12 to 48Vdc, the power connection must be made directly to the VLIO Board, which connects to and powers the ULP.



Protection against Electrostatic Discharges and Surge: The VLIO Board has protection against voltage surges in the 12 to 48Vdc power supply, acting in cases of overvoltage or electrostatic discharge in the opto-isolated inputs and outputs (IOs) and in the 24Vdc power supply line. These protections comply with IEC 61000-4-2 (ESD) with supportability of $\pm 8\text{kV}$ (ESD) and 48Vrms (overvoltage) on all inputs and outputs (IOs).



Maximum voltage at the IOs terminals of the VLIO Board: The maximum supported voltage at each INPUTS, OUTPUTS, and IOVcc-IN terminal is 48Vdc.



Place of Installation: In cases where it is not possible to meet the installation specifications, it is recommended to consult Pumatronix Technical Support.

Models

Models available	Resolution	Lens Type	Estimated range (in meters)
VIGIA-VL (S10L7IWOP)	1920x1080 - Rolling Shutter Full HD	Motorized lens	9 a 32m (2.7-12mm)

Image sensors	Lens	Integrated Lighting	Optional
S10: CMOS IMX307 1920x1080	L7: Motorized lens 2.7-12MM	I: Infrared	P: POE power supply

Summary

1.	Getting to know the product.....	7
	Monitoring Set	7
2.	Additional Documentation	8
3.	Information Generated	8
4.	VL-Sensor-D Image Capture and Processing Device	9
	Mechanical Specifications.....	9
	Features.....	9
	Electrical Specifications.....	9
5.	VIGIA-VLIO Controller Module.....	10
	New VIGIA-VLIO Controller Module.....	10
	Mechanical Specifications	10
	Features.....	11
	Electrical Specifications.....	11
	VIGIA-VLIO Controller Module.....	12
	Mechanical Specifications	12
	Features.....	12
	Electrical Specifications.....	13
	Output Ports.....	15
	Status LEDs.....	15
	Electrical Connections.....	15
	Electrical Connections of the New Controller Module with the Traffic Light Controller	17
	Electrical Connections of the Controller Module with the Traffic Light Controller.....	17
6.	Software Specifications	20
	Start Screen Control Panel	20
	VL-Sensor-D Image Capture and Processing Device	20
	VIGIA-VLIO Controller Module and Monitoring Set.....	20
7.	Licensing	20
8.	Initial Setup.....	21
	Installation Requirements	21
	Conditions Required for Installation	21

9.	Installation	21
	Monitoring Set Installation	21
	Post Positioning with Projected Arm.....	22
	VL-Sensor-D Image Capture and Processing Device Attachment	22
	Monitoring Set Connections.....	23
	VIGIA-VLIO Controller Module Installation	23
	Attaching the VIGIA-VLIO Controller Module	24
	Data Connections	25
10.	First Access VIGIA-VL Web Interface	26
	First Access VL-SENSOR-D	26
11.	Care and Maintenance	26
	Firmware Update	26
	Preventive Maintenance.....	27
	Preventive Electrical Maintenance	27
	Preventive Maintenance of the VL-SENSOR-D Image Capture and Processing Device Fixture	27
	Preventive Maintenance of the Protection Tab of the VL-SENSOR-D Image Capture and Processing Device.....	27
	Preventive Maintenance of the VL-SENSOR-D Image Capture and Processing Device Lenses.....	28
12.	General Conditions of the Warranty	28
	Situations in which the Product Loses the Warranty	28
13.	Privacy Policy.....	29

1. Getting to know the product

The VIGIA-VL solution consists of a set of equipment and software that monitor the flow of vehicles, detecting traffic in the Virtual Loop regions configured through the interface, and providing the vehicle count per detected class. The product enables the communication with the existing Traffic Light Controller system, for sending the signals of the virtual loops. It can be installed in new or existing structures.

Monitoring Set

The VIGIA-VL can use one to eight image capture and processing devices, installed individually on each track with up to 4 lanes, connected to a PoE switch and a VIGIA-VLIO Controller Module, which interconnects the solution to the Traffic Light Controller.

Each *Monitoring Set* is composed of:

- 1 VL-SENSOR-D image capture and processing device;
- 1 Pole Support with metallic straps (Vertical or Horizontal);
- 1 controller module VIGIA-VLIO or the New VIGIA-VLIO Controller Module.

When using the VIGIA-VL, a path of up to 4 lanes is monitored by a single VL-SENSOR-D image capture and processing device. Thus, four-way monitoring requires four VL-SENSOR-D image capture and processing devices, totaling sixteen monitored tracks.

Installed with the Pole Bracket, each monitoring point must be connected to the PoE Switch and the VIGIA-VLIO Controller Module, which receives vehicle detection events and generates signals for the Traffic Light Controller.

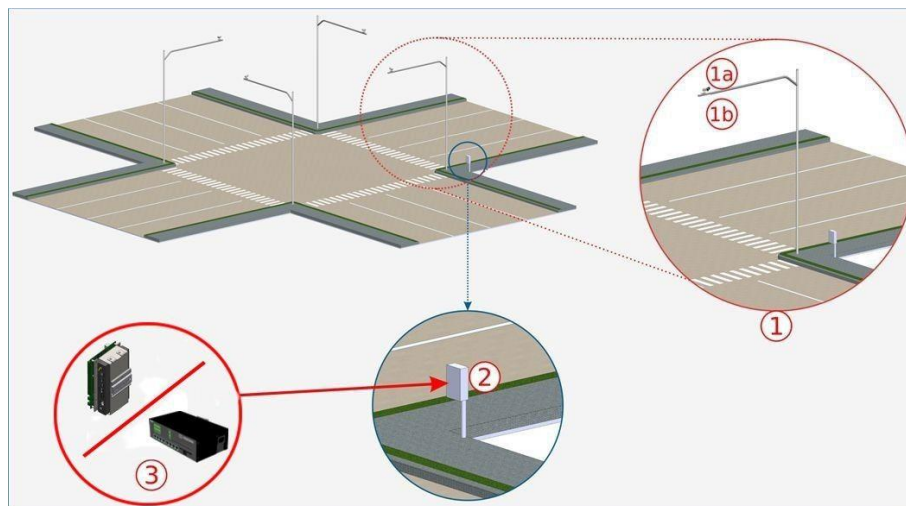

Figure 1 - Example of VIGIA-VL installation: 1) Monitoring Set; 1a) VL-SENSOR-D; 1b) Pole Support Pole; 2) Semaphore Controller Command Board; 3) Controller Module VIGIA-VLIO

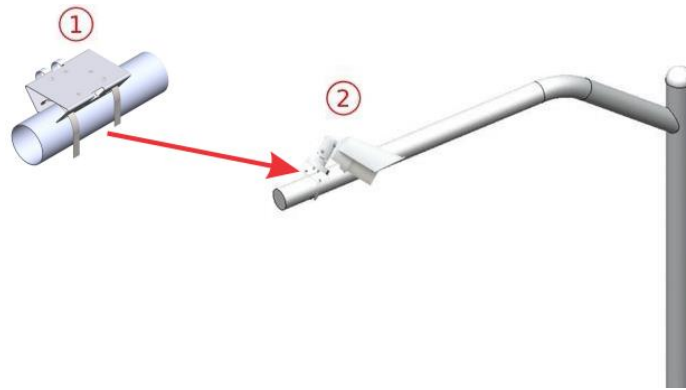

Figure 2 - Monitoring Set, installed on pole with projected arm: 1) Pole Support (horizontal installation);
2) VL-SENSORr-D Device

2. Additional Documentation

Document	Link	Description
VIGIA-VL Installation Guide	Installation Guide	Guide for installing the VIGIAVLIO Monitoring Set and Controller Module components
VIGIA-VL Integration Manual	Integration Manual	Programming and integration manual containing the necessary information for integrating VIGIA-VL with an application

3. Information Generated

VIGIA-VL can be used in traffic management because it processes and analyzes the images captured by the VL-SENSOR-D capture and processing devices. This analysis identifies the vehicles, based on the detection by the Virtual Loops bounded in the images and the result is presented in the form of:

- Counting of vehicles that passed in the monitored tracks, at night and day, with optimized performance for locations where the average speed of vehicles is 60km/h;
- Activation in real time of the LEDs (located near the outputs of the VLIO Board), that indicate the Occupation of the virtual loop or the Count by pulses in the monitored tracks, with configurable duration. These LEDs also represent the state of the Virtual Loops;
- Passages Report, based on the detection records of the virtual loops. In this report the following information is presented by record:
 - Classification, from the options Motorcycle, Car, Bus, Truck, and Unidentified;
 - Image of the vehicle passage;
 - Virtual loop passage counter;
 - Estimated speed, when enabled and configured;
 - Moment of passage (date and time);
 - Capture device in which it was detected;
- Input region in which motion detection started;
- Active region indicating the virtual loop in which the vehicle passage was completed.
- A message in JSON format containing the vehicle passage counters, the Estimated Current Speed and the Estimated Average Speed (this message is sent according to the Web Service REST settings);

- Message in Socket Protocol containing a 32-bit integer, where each bit represents one of the loops (the sending periodicity is 250ms).

4. VL-Sensor-D Image Capture and Processing Device

Mechanical Specifications

The VL-Sensor-D Device model has a cable with RJ-45 interface for power and data connection.



Features

- Degree of Protection: IP66
- Material:
 - VL-SENSOR-D Body: Aluminum
 - Front cover: Polycarbonate with UV protection
- Weight: 872g
- Fixation: 3/16" diameter screws
- Support: With 360° movement, in all axes (positioning/tilting adjustment)
- Mechanical Protection: Adjustable tab (protect lenses from direct sunlight)
- Operating Temperature: -10°C to 65°C
- Transmission Rate: 1 to 60fps
- Communication Interface: Ethernet 10/100Mbps

Electrical Specifications

- Maximum Consumption: 12,95W

The VL-Sensor-D Device is powered through the PoE (Power over Ethernet) connection with the AC/DC, DC/DC and Auxiliary Control Board.

5. VIGIA-VLIO Controller Module



Figure 3 - New VIGIA-VLIO Controller Module

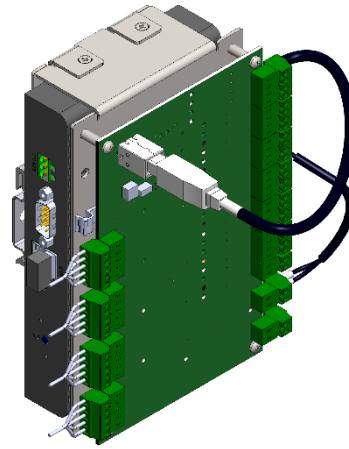

Figure 4 - VIGIA-VLIO Controller Module

There are two models of the VIGIA-VLIO Controller Module available, with different installations, connections and interfaces. The New Controller Module has a faster and more simplified installation, as it brings together all the necessary connections in just one device. The other Controller Module consists of 1 VIGIA-VLULP (Firefly), 1 VLIO Board and 1 PoE Switch, independent. Check out the specifications of each model below:

New VIGIA-VLIO Controller Module

The New VIGIA-VLIO Controller Module is responsible for interconnecting the VIGIA-VL with the Traffic Light Controller of the intersection or traffic light. It has the ability to receive signals from up to eight image capture and processing devices and send signals from up to sixteen monitored lanes to the Traffic Light Controller.

Mechanical Specifications

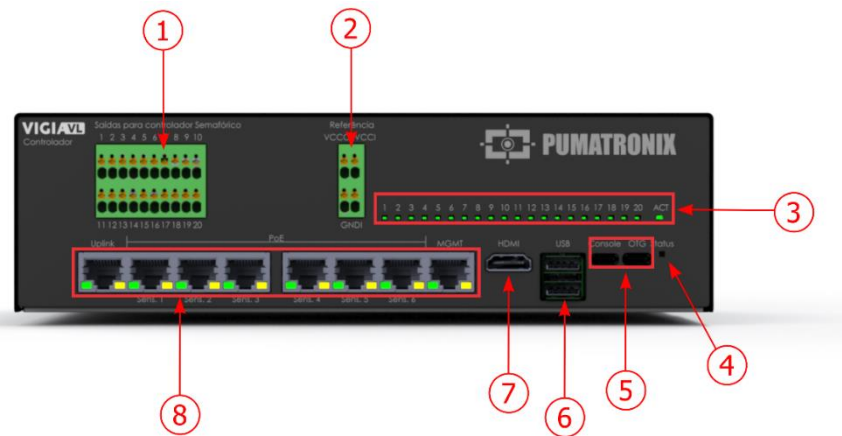

Figure 5 - Interfaces of the New VIGIA-VLIO Controller Module: 1) Outputs for traffic light controller; 2) Connections for powering the IOs; 3) LEDs indicating Output signals; 4) Status LED; 5) microUSB and USB-C inputs; 6) USB input; 7) HDMI input; 8) 6-port PoE Switch

The module structure allows it to be fixed to the Traffic Light Controller frame, using the attached supports, as shown in the figure:

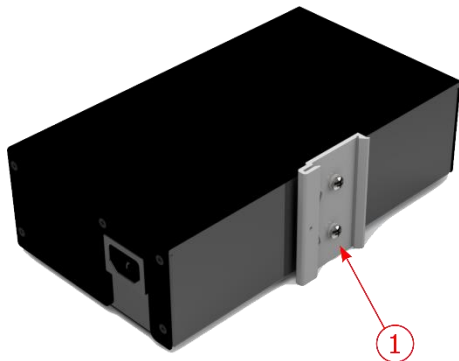

Figure 5 - 1) DIN rail support

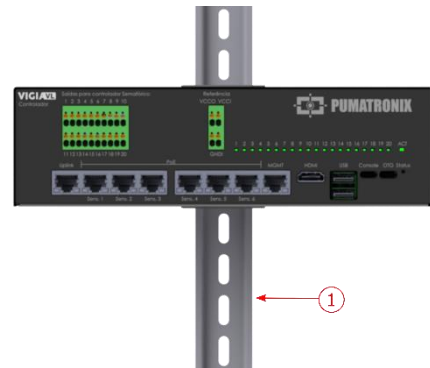

Figure 6 - 1) DIN rail

Features

- Fixing: DIN Rail
- Dimension: 233 x 66.5 x 130mm
- Operating temperature: -10°C to 65°C
- Weight: 1,350kg

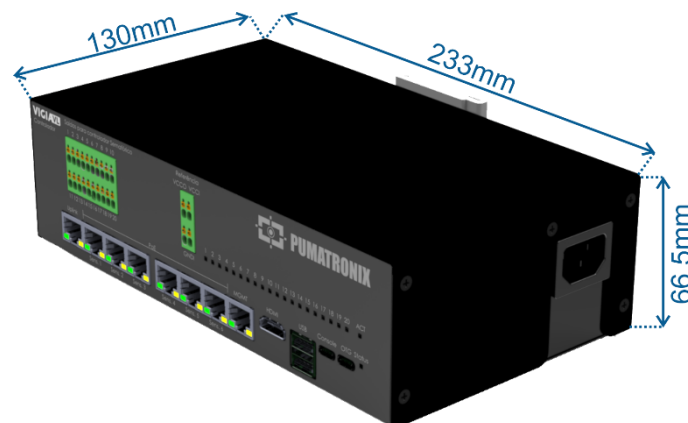

Figure 8 - New VIGIA-VLIO Controller Module dimensions



Fixing of the VIGIA-VLIO Controller Module: The module should be fixed on a panel, preferably the one existing on the Semaphore Controller's frame.



Caution when installing the VIGIA-VLIO Controller Module: As it has no protection against dust and water penetration, this module cannot be exposed outdoors, subject to weather conditions, and must be installed in a sheltered place.

Electrical Specifications

- Power: 85 ~ 265 Vac
- Maximum consumption: 130W



Figure 9 - Power connector (AC cable)

VIGIA-VLIO Controller Module

Mechanical Specifications

The VIGIA-VLIO Controller Module consists of:

- 1 VIGIA-VLULP (Firefly);
- 1 Board VLIO
- 1 Switch PoE.

The connection between VLIO and VIGIA-VLULP(Firefly) is made through USB connection.

The VIGIA-VLIO Controller Module is responsible for interconnecting the VIGIA-VL with the Traffic Light Controller of the intersection or traffic light. It is capable of receiving the signals from up to eight Monitoring Sets, and sending the signals from up to sixteen monitored tracks to the Traffic Light Controller.

The module's structure allows for attachment to the Semaphore Controller's frame, using the attached brackets, as indicated in the figure:

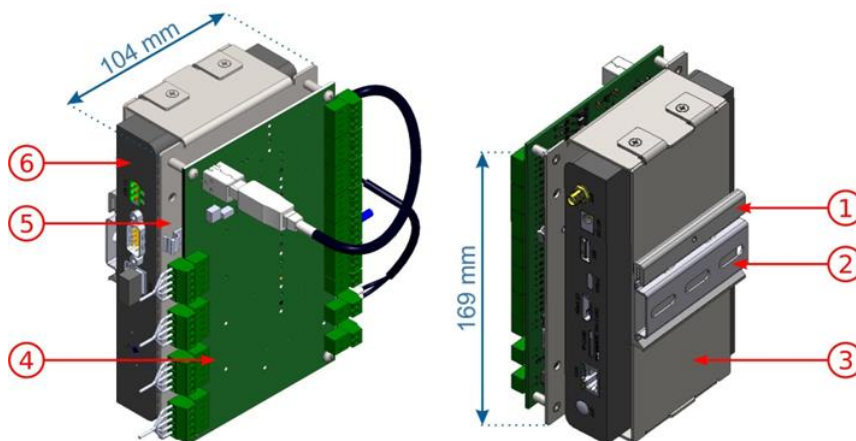

Figure 10 - VIGIA-VLIO Controller Module: 1) DIN Rail Support; 2) 75mm DIN Rail; 3) ULP Bottom Support; 4) VLIO plate; 5) ULP VL top bracket; 6) ULP

Features

- Communication: RJ-45 serial for data and USB for maintenance
- Fixation: DIN rail

- Dimension: 169 x 104mm
- Operating temperature: -10°C to 65°C
- Weight: 1Kg



Fixing of the VIGIA-VLIO Controller Module: The module should be fixed on a panel, preferably the one existing on the Semaphore Controller's frame.



Caution when installing the VIGIA-VLIO Controller Module: As it has no protection against dust and water penetration, this module cannot be exposed outdoors, subject to weather conditions, and must be installed in a sheltered place.

Electrical Specifications

- Power supply: 12~48Vdc
- Maximum Consumption: 13W



Power Supply to the VIGIA-VLIO Controller Module: To power the module with a voltage of 12 to 48Vdc, the power supply must be connected directly to the VLIO Board, which connects to and powers the ULP, as indicated. The points indicated in the figure should be used, with connectors P4 and Terminal Block. To power the isolated IOs from the VLIO Board, check the restrictions and the step by step installation process for more details.

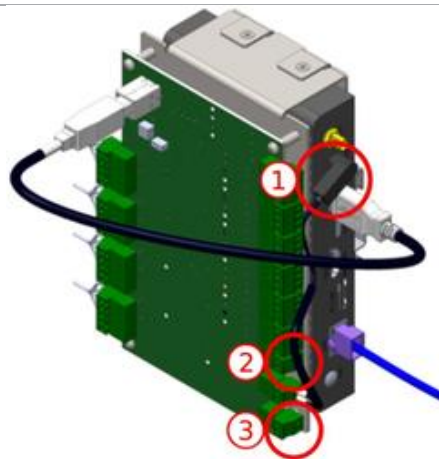

Figure 11 - Power connections on the VLIO Board: 1) Power supply to the VIGIA-VLIO Controller Module; 2) Power supply to the isolated IOs on the VLIO Board; 3) Power supply to the VLIO Board

To power this module, it is recommended to use a power supply that meets the requirements:

- Operating temperature: -40 to 85°C;
- Output Voltage: 24Vdc;
- Current: 4A;
- DC Output Voltage (24V) Regulation Limit: +/-2%;
- Reverse polarity protection;
- Output Ripple Noise: 120 mVpp;
- Overload protection: 110 to 150%;
- Overvoltage protection: 120% to 140%;
- Meet standards: IEC 6236801 (LVD), AS/NZS 62368.1, EN55032 (conducted emissions - Class B), EN55032 (radiated emissions - Class B) and EN61000-3-3 (voltage pickup), EN6100-4-2 (ESD), EN6100-4-3 (radiated immunity), EN6100-4-4-4 (EFT/Burst), EN6100-4-5 (voltage surge), EN6100-4-6 (conducted immunity) and EN6100-4-8.

Switch PoE

- 110V power supply

The VL-SENSOR-D and the Controller-VLIO Module connect to the PoE switch via an Ethernet cable. If there is external access, another Ethernet cable must connect the PoE switch to the access point.



Figure 12 – 8 port PoE Switch

VLIO Board

- 24Vdc power supply

The VLIO Board is responsible for interconnecting the VIGIA-VL with the Traffic Light Controller, sending the track occupancy information to the controller system through dry contacts. In the same way, the VIGIA-VL operation can be controlled through the interfaces available on the VLIO Board, which have different behaviors and functions:

- 16 opto-coupled isolated 48Vdc and 100mA (maximum) outputs (for interfacing with the Traffic Light Controller);
- 12Vdc output and 2A (maximum) for power supply of the VIGIA-VLIO Controller Module;
- Power input to the isolated opto-coupled outputs (for interfacing with the Traffic Light Controller);
- VLIO Board power input (to power the VIGIA-VLIO Controller Module with 12~48Vdc voltage, the power connection must be made directly to the VLIO Board and ULP);
- Equipotential grounding;
- USB connection (for data transmission);
- ERROR and STAT LEDs (to indicate the operation of the equipment);
- LEDs indicating the individual activation of the outputs.



Figure 7 - VLIO Board Interfaces: 1) Power Inputs; 2) Output connection for Firefly (ULP) power; 3) Board grounding (must be connected to the GND of the Installation); 4) USB data connection; 5) ERROR and STAT LEDs; 6) LEDs indicating Output signals; 7) Signal outputs to the Traffic Controller



Protection against Electrostatic Discharges and Surge: The VLIO card has protection against voltage surges in the 24Vdc supply, acting in case of overvoltages or electrostatic discharges on the opto-isolated inputs and outputs (IOs) and on the 24Vdc supply line. These protections comply with IEC 61000-4-2 (ESD) with supportability of $\pm 8\text{kV}$ (ESD) and 48Vrms (overvoltage) on all inputs and outputs (IOs).

Output Ports

To send the monitoring data to the Traffic Light Controller, 16 outputs of the VLIO Board are used. By interconnecting, the signals sent can be used by the Traffic Light Controller to activate the traffic light and consequently release the flow of traffic on the site.

Each output port has a corresponding LED, which lights up when active and remains off when inactive.



Polarity change: Changing the polarity of the OUTPUTs ports implies in reversing the product's operation logic. Check the IO LEDs to validate the configuration.

Status LEDs

The red LED named *ERROR*, is intended to indicate errors in the operation of the board; the green LED named *STAT*, indicates normal board activity. By analyzing the behavior of the LEDs, information about the system can be obtained, as detailed in the tables below.

- Information provided by the *ERROR* (Red) LED:

Behavior	Meaning
Deleted	Normal System Operation
On for 5s and blinks once	Received packet error: The received packet is invalid, malformed, or the requested function is not implemented. This error remains until a valid packet is received by the VLIO Board.
Lit for 5s and blinks 4, 5 or 6 times	Hardware error: Triggering/reading the outputs/inputs cannot be done. The board must be powered off and powered on again. If the problem persists, please contact Technical Support.

- Information provided by the *STAT* (Green) LED:

Behavior	Meaning
Blinks 1 time per second	No communication between Monitoring Set and VLIO Board or between ULP and VLIO Board
Flashes 5 times per second	Traffic of data packets between the units or between ULP and VLIO Board VLIO CARD

Electrical Connections

For the connections between each Monitoring Set and the VIGIA-VLIO Controller Module, cables and interfaces as specified in the connection diagram should be used, with the capacity to connect up to 4 Monitoring Sets in total:

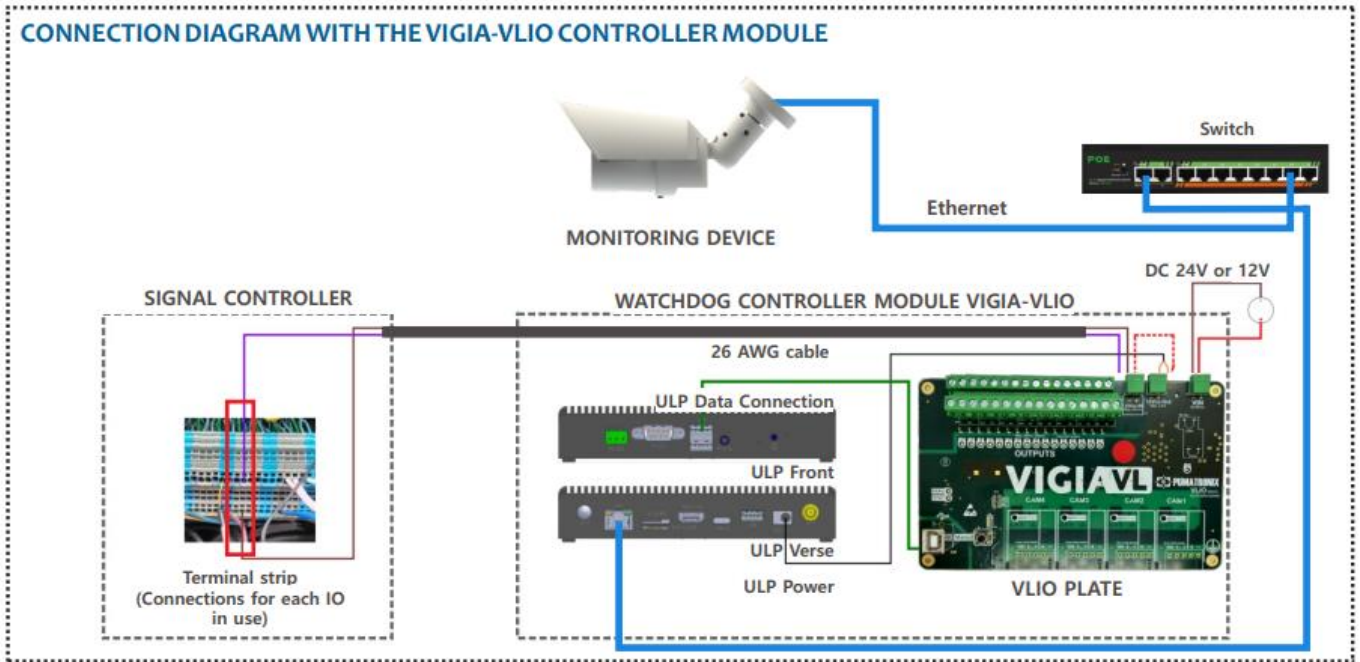

Figure 14 - Connection diagram of VIGIA-VL with a Monitoring Set

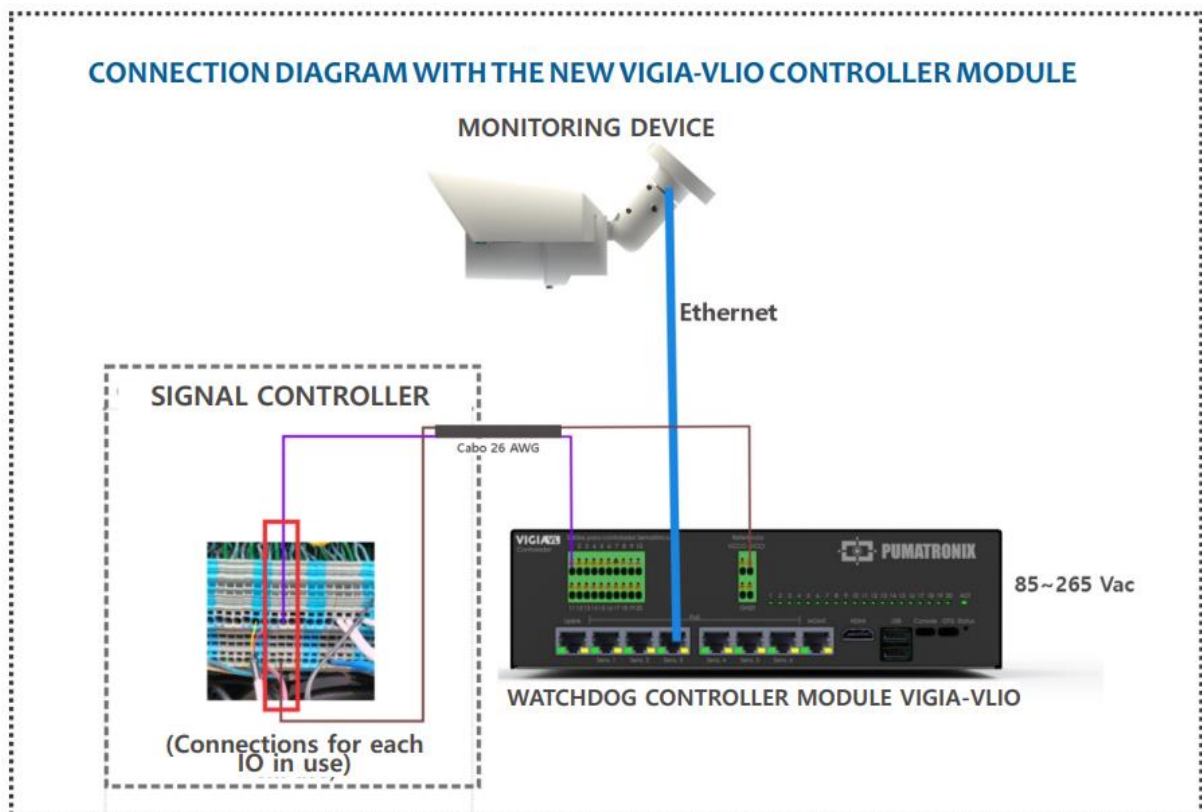

Figure 15 - VIGIA-VL connection diagram with the New Controller Module



Data connection: The RJ-45 serial interface is used for communicating data from the Monitoring Set to the VIGIA-VLIO Controller Module.

Electrical Connections of the New Controller Module with the Traffic Light Controller

The New VIGIA-VLIO Controller Module is powered by the Traffic Light Controller, when connected to the VCCI input. For this connection, use a 26AWG 2-way cable, crimping the ends with a 1mm tubular terminal.

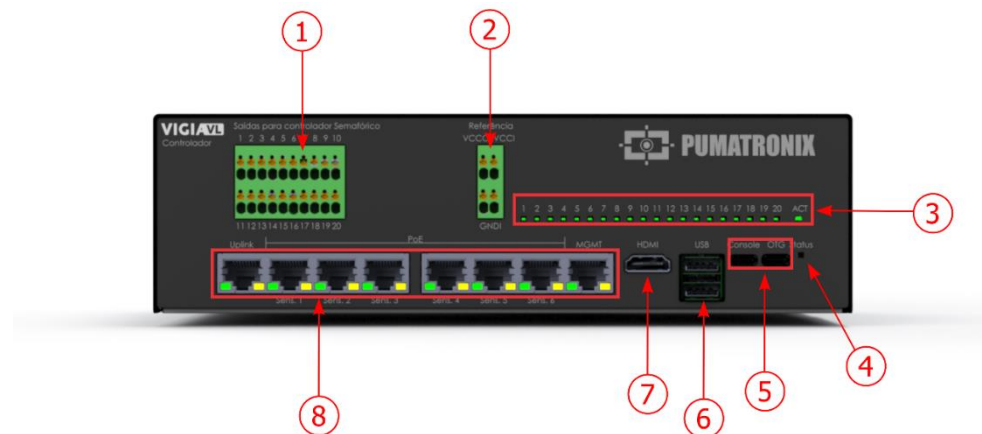

Figure 16 - Interfaces of the New VIGIA-VLIO Controller Module: 1) Outputs for traffic light controller; 2) Connections for powering the IOs; 3) LEDs indicating Output signals; 4) Status LED; 5) microUSB and USB-C inputs; 6) USB input; 7) HDMI input; 8) 6-port PoE Switch



Traffic Light Controller board type: The outputs for the traffic light controller of the New Controller Module do not allow connection to inductive loop boards.

Identify the model of the existing Traffic Light Controller at the location, to connect the Outputs to the Traffic Light Controller of the New Controller Module. Perform the steps indicated using 26AWG 2-way cables in the connections and the ends crimped with a 1mm tubular terminal:

- 1) Connect the negative (-) Vcc-IN on the New Controller Module to the common input terminal of the Semaphore Controller's dry contact board;
- 2) Connect an Output signal for the traffic light controller of the New Controller Module to a signal terminal on the dry contact board of the Traffic Light Controller;
- 3) Repeat steps 1 and 2 for each Output for the traffic light controller of the New Controller Module, knowing that each common signal on the dry contact terminals of the Traffic Light Controller corresponds to only one signal input, as they are individual and isolated;
- 4) Check the status of the pulses through the LEDs of the New Controller Module and the Traffic Light Controller, which must indicate the presence of vehicles in the virtual loops and must be synchronized.



Functioning of the virtual loop signal LEDs: If the Semaphore Controller LEDs are not indicating receipt of the virtual loop signal, contact Technical Support.

Electrical Connections of the Controller Module with the Traffic Light Controller

The VIGIA-VLIO Controller Module is powered by the Traffic Light Controller by connecting to the VIN terminal of the VLIO Board. For this connection, use a 26AWG 2-way cable, crimping the ends with a 1mm ferrule.

The ground connection should be made on the surface of the VLIO Board, using a 0.7mm² flexible cable crimped with a 0.7mm fork terminal.

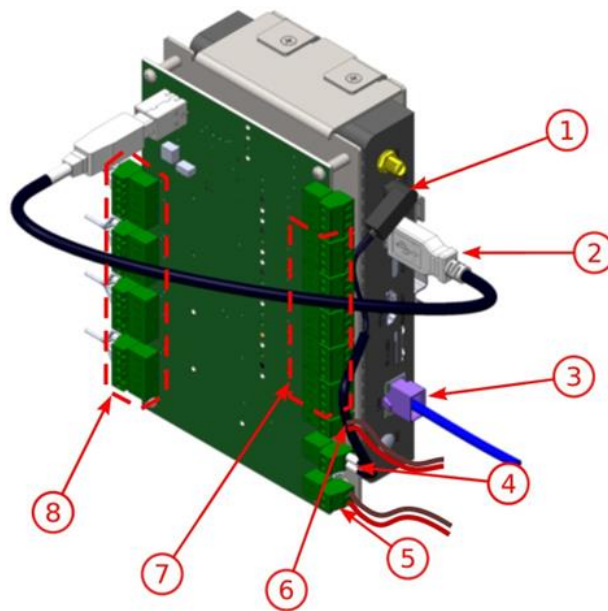

Figure 17 - Connections of the VIGIA-VLIO Controller Module: 1) Power supply of the ULP; 2) USB (internal connection); 3) Ethernet (configurations); 4) ULP power supply; 5) Power supply of the VIGIA-VLIO Controller Module; 6) Power supply of the isolated outputs; 7) Outputs (connection with the Traffic Light Controller);



Semaphore Controller Board Type: The output signals from the OUTPUTS terminals of the VLIO Board do not allow connection to inductive loop boards.

Identify the Semaphore Controller model existing on site and the operation of the respective dry contact board to connect and power the isolated inputs (INPUTS) and outputs (OUTPUTS) of the VLIO Board. Perform the indicated steps using 26AWG 2-way cables in the connections and crimped ends with 1mm tubular terminal:

- 1) Check for any DC voltage level across the signal and common input terminals of the Semaphore Controller dry contact board with the aid of a multimeter. If DC voltage level is detected between the signal and common input terminals of the Semaphore Controller board, only the negative (-) contact of the IOVcc-IN terminal block remains connected on the VLIO Board;
- 2) Connect the negative (-) on IOVcc-IN on the VLIO Board to the common input terminal of the Semaphore Controller's dry contact board;
- 3) Connect an OUTPUTS output signal from the VLIO Board to a signal terminal of the Semaphore Controller's dry contact board;



- 4) Copy the port ID used for the Facility Mapping;
- 5) Connect the positive (+) of the IOVcc-IN terminal block with the positive (+) of the 12Vcc-Out terminal block only when there is no voltage level at the signal terminals and the common input of the Traffic Light Controller board. This connection has the purpose of powering the isolated outputs (OUTPUTS) of the VLIO Board where an additional cable (crimped with a 1mm tubular terminal at the ends) must be used;

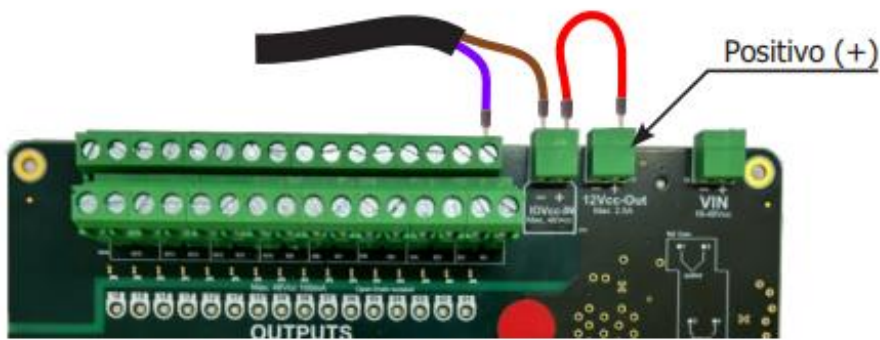

- 6) Repeat steps 2 and 3 for each output signal from the VLIO Board, knowing that each common signal on the Semaphore Controller's dry contact terminals corresponds to only one signal input, since they are individual and isolated;

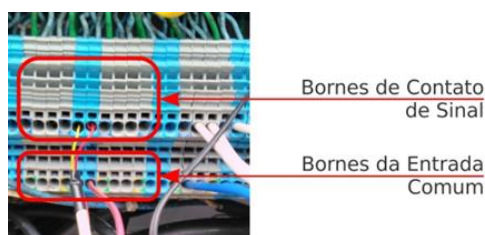

- 7) Check the status of the pulses through the LEDs of the VLIO Board and the Traffic Light Controller, which should indicate the presence of vehicles in the virtual loops and should be synchronized. If an error occurs in synchronization, check how to configure in **Configuration of the VIGIA-VLIO Controller Module**.



Functioning of the virtual loop signal LEDs: If the Semaphore Controller's LEDs are not indicating receipt of the virtual loops signal, contact Technical Support.

6. Software Specifications

Start Screen Control Panel

In order for the home screen of the Control Panel to display the image of a connected and previously configured VL-SENSOR-D image capture and processing Device, it must be selected from the gear icon in the upper right corner of the screen.

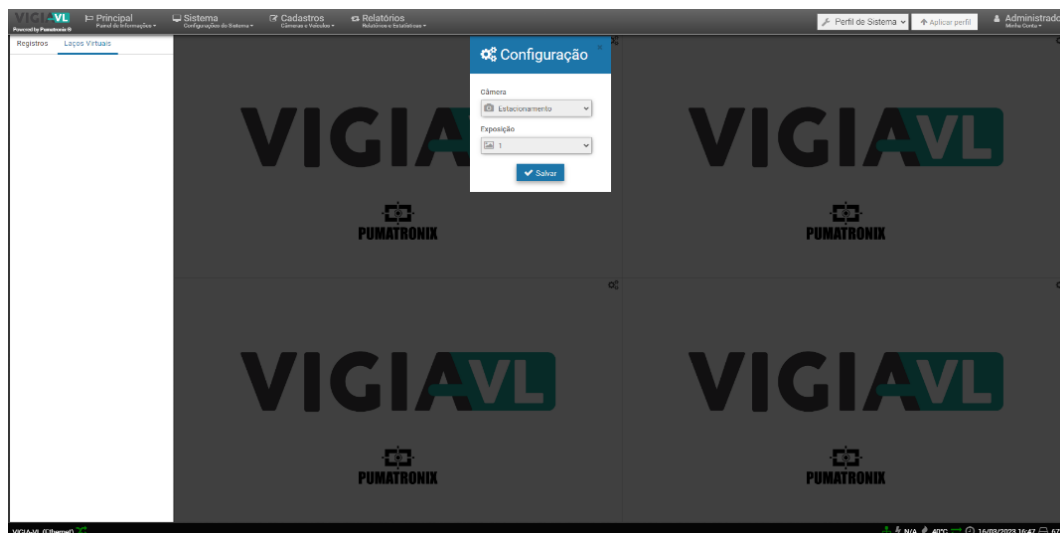

Figure 18 - Configuring the Interface Start Screen

VL-Sensor-D Image Capture and Processing Device

The VL-Sensor-D Capture Device can be configured via its Web interface, using a browser-based Device:

- Microsoft Edge
- Chrome
- Firefox
- Safari

VIGIA-VLIO Controller Module and Monitoring Set

To access the VIGIA-VL software interface, a Device with Google Chrome browser version 56 or higher installed is required.

7. Licensing

The VL-SENSOR-D license is a single file and associated with the hardware on which the system has been installed. The VIGIA-VL system supports the processing of a maximum of eight VL-Sensor-D devices simultaneously connected to the network for data communication to the Traffic Lighting Controller.



Information distribution: The content generated by VIGIA-VL is user and password protected. However, the system administrator is responsible for controlling which users have access to the information and the dissemination of the content.

8. Initial Setup

Installation Requirements

The VIGIA-VL requires the following features to function properly during operation:

- Electric Network, providing 110/220Vac power supply;
- Pole, used one for each Monitoring Set, which allows the components to be fixed and the captures to be made at a height of 6.00m;
- Cable protection piping, between the Monitoring Set and the VIGIA-VLIO Controller Module, in order to protect the electrical installation and the data network;
- Cabling, used for electrical and data connections, considering the maximum length for each type;
- Additional Ethernet cable, to allow for adjustments in each monitoring point and in the VIGIA-VLIO Controller Module;
- Multimeter, to check if there is voltage at the existing terminals in the Semaphore controller model where the VIGIA-VLIO Controller Module will be connected.

Conditions Required for Installation

- The site chosen for installation must make it possible to position the VL-Sensor-D image capture and processing device so that the images produced are free of regions covered by architectural structures, trees, vehicles from other lanes, among other elements. The equipment has a sliding flap, which prevents direct sunlight from falling on the lens and obscuring the image;
- Sheltered place in the installation of the VIGIA-VLIO Controller Module;
- DIN rail support for fixing the VIGIA-VLIO Controller Module;
- Sheltered place that protects the port connections of the VIGIA-VLIO Controller Module with the Traffic Light Controller.

9. Installation

Once the prerequisites and conditions for the complete installation of the selected VIGIA-VL model have been met, the components can be installed according to the specifications presented. It is recommended to first physically install the components and then configure them via the interface with the help of a laptop.

Monitoring Set Installation

To install a Monitoring Set, you need a pole that offers the best positioning for capturing images of the tracks.



Installation of the VL-Sensor-D Device on the side of the track: Vehicles in the image may suffer occlusion, especially those traveling in the far lane, which may result in an incorrect vehicle count.

The distance of the *Monitoring Set* from the VIGIA-VLIO Controller Module may require a longer cable length for the data connection, which reduces the data transmission speed proportionally.

To assemble the components of a Monitoring Assembly in an orderly fashion, it is recommended that you follow the indicated sequence of operations, detailed step-by-step:

- 1) Install the Pole;
- 2) Prepare the Ethernet cable from the VL-SENSOR-D Device;

- 3) Attach the VL- SENSOR -D to the Pole;
- 4) Correct the alignment of the VL-Sensor-D;
- 5) Connect the Ethernet cable to the Control Board;
- 6) Make the electrical connections to the model of the control panel used;
- 7) Make the data connection to the VIGIA-VLIO Controller Module.

Post Positioning with Projected Arm

The position of the pole in relation to the track must allow the image capture of vehicles to occur at the ideal distance of 6.00 meters in height in relation to the rolling road of vehicles, for the best framing of the tracks of interest. To define the installation site, the following are used as reference: the installation height of the image capture and processing device VL-Sensor-D and the angle of the equipment in relation to the track, which is 30° to 45° when installed on the projected arm of the pole. In this condition, the maximum vehicle detection distance is 18 meters from the imaging device.

To position the pole with the projected arm or to install it on an existing structure, the indicated distances must be observed, because they guarantee a good definition of the collected image, generating efficiency in the detection of the presence of vehicles by the virtual ties.

Mark the monitoring area's central point on the road, at a distance in between 3.50 and 6.00 meters from the pole alignment and install the pole's projected arm at a height of 6.00 meters in relation to the vehicle's travel lane, to fix the Pole Support and the VL-SENSOR-D Device. The framing adjustment is done by visualizing in the center of the image the marking made on the track, through the VL-SENSOR-D interface. This means that the VL-SENSOR-D Device must be installed at a 30° to 45° angle to the track. The figure illustrates this installation situation.

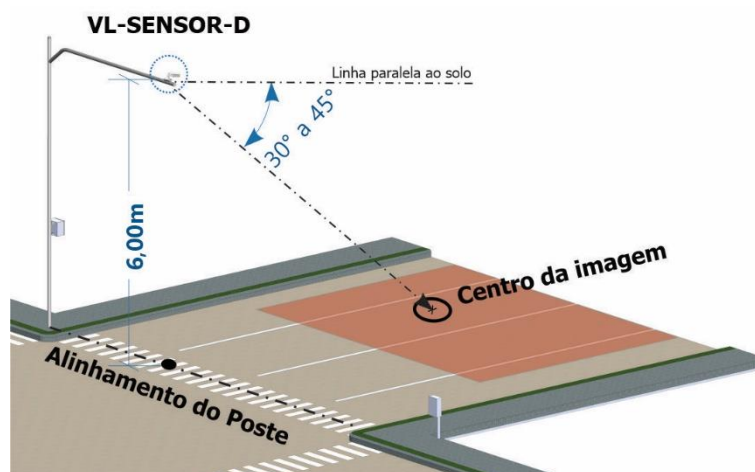
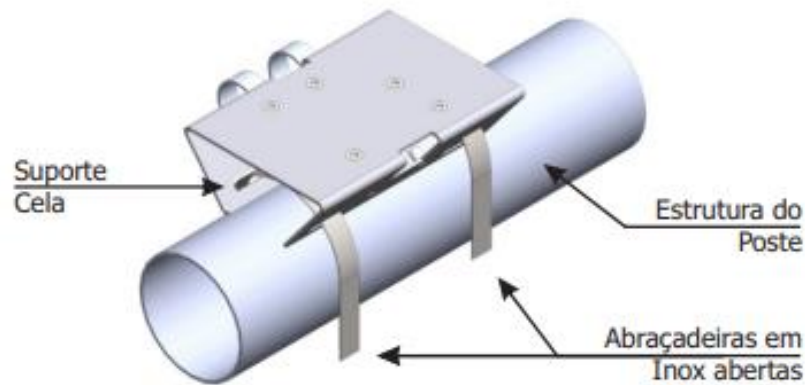

Figure 19 - Positioning the Pole with the Projected Arm and the VL-Sensor-D Device

VL-Sensor-D Image Capture and Processing Device Attachment

The VL-SENSOR-D Image Capture and Processing Device must be attached to a cell holder, provided with the equipment.



- 1) Install the Pole;
- 2) Prepare the Ethernet cable from the VL-SENSOR-D Device;
- 3) Install the cell holder by resting it on the projected arm of the pole and insert the clamps on the holder, wrapping the pole.
- 4) Align the surface of the pole holder with the track plane.
- 5) Secure the bracket to the post by closing the clamps and screwing the bolts in place with a 7 mm spanner;
- 6) Place the VL-SENSOR-D Image Capture and Processing Device on the support;
- 7) Slightly loosen the arm ball screw;
- 8) Fix the VL-SENSOR-D position by screwing the screws;

Installing the Coupling Connector

When installing the VL-SENSOR-D image capture and processing device, the connector with RJ-45 interface is used for the Ethernet connection to the control panel. This connection should be made by preparing the cable as shown:

- 1) Cut the Ethernet cable long enough to connect the VL-SENSOR-D Device to the Control Board;
- 2) Run the Ethernet cable;
- 3) Crimp the RJ-45 end of the cable to EIA/TIA 568A standard;
- 4) Connect the Ethernet cable to the RJ-45 interface of the VIGIA-VL cable.

Monitoring Set Connections

The installation of a VIGIA-VL Monitoring Set requires the VL-SENSOR-D Device connections to the VIGIA-VLIO Controller Module, for sending the data.



Distance from the VIGIA-VL Device to the Switchboard: The length of the Ethernet cable between the Device and the Command Board should be less than 100m.

VIGIA-VLIO Controller Module Installation

For interconnection with the Traffic Light Controller, the VIGIA-VLIO Controller Module should be installed in a sheltered location, such as the existing Traffic Light Controller's chassis, so that access for maintenance can be facilitated. For this, the frame panel should have a DIN rail with enough space for fixing the module, or enough space to fix the 75mm long DIN rail. In addition, sufficient space must be provided to accommodate cables and connections for up to eight Monitoring Kits with the Traffic Light Controller.



Caution when installing the VIGIA-VLIO Controller Module: As it does not have protection against dust and water penetration, this module cannot be exposed outdoors, subject to weather conditions, and must be installed in a sheltered place.

Attaching the VIGIA-VLIO Controller Module



Fixing of the VIGIA-VLIO Controller Module: The module should be fixed on a panel, preferably the one existing internally to the Traffic Light Controller's frame.

The support structure of the *VIGIA-VLIO Controller Module* allows it to be fixed in different positions using a DIN rail. The factory default vertical position is preferred as it allows the best view of the state of the connections on the VLIO Board and makes it easier to manipulate the connections. To change to the other possible fixing positions, some procedures are required to adapt the structure:

Standard Vertical Mounting

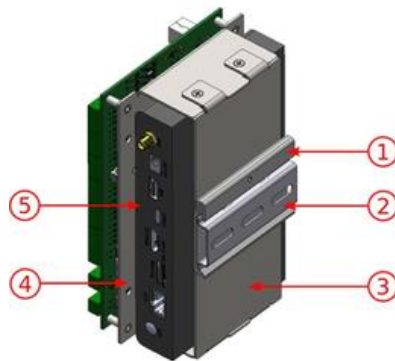
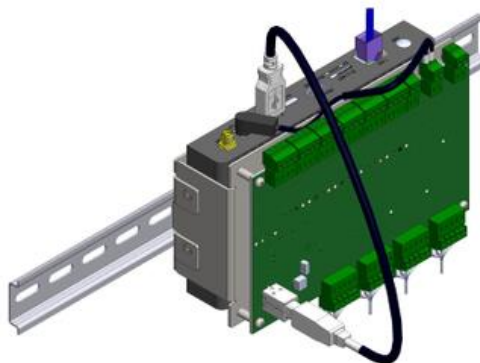

Figure 20– 1) DIN Rail Support; 2) DIN Rail 75mm; 3) Bottom Support; 4) Top Support; 5) ULP

- 1) Remove the supplied 75mm DIN Rail from the frame, if there is a rail for fixing;
- 2) Allow enough space to accommodate the cables and connections;
- 3) Fit the VIGIA-VLIO Controller Module on the panel rail

Horizontal Fixation



- 1) Remove the 2 screws that attach the DIN Rail Bracket to the module;
- 2) Perpendicular to the original position, attach the DIN Rail Bracket to the Bottom Bracket of the module (using the 2 screws);
- 3) Snap the module onto the panel rail.

Profile Fixing

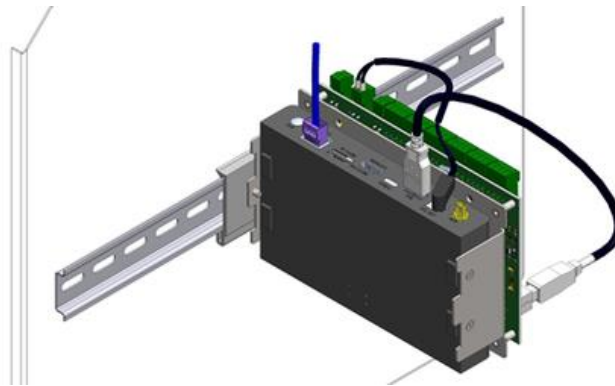

- 1) Remove the DIN Rail Bracket (undo 2 screws) and the Bottom Bracket (undo 4 screws);
- 2) By removing the 4 screws from the Bottom Bracket, the ULP detaches from the frame;
- 3) Secure the ULP to the Upper Bracket with the 4 screws;
- 4) Attach the DIN Rail Bracket to the side of the module, on top of the Top Bracket;
- 5) Snap the module onto the panel rail.

Fixing New Controller Module

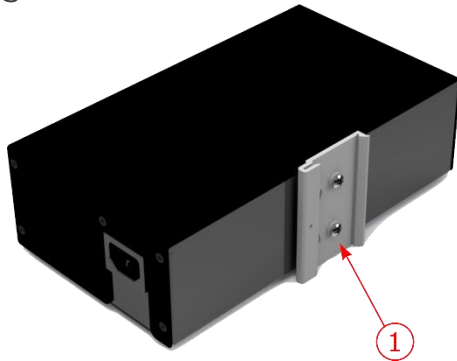

Figure 21 - 1) DIN rail support

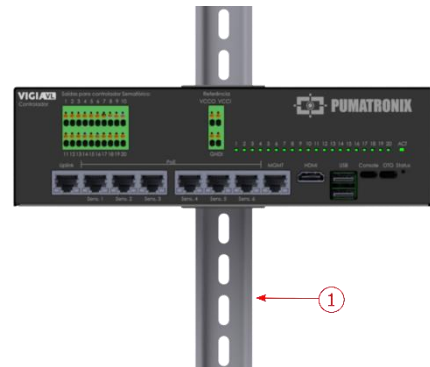

Figure 22 - 1) DIN rail

- 1) Remove the 75mm DIN Rail supplied from the structure, if there is a rail for fixing;
- 2) Reserve enough space to accommodate cables and connections;
- 3) Fit the New VIGIA-VLIO Controller Module onto the panel rail.

Data Connections

The data connection is necessary between the Monitoring Set and the *VIGIA-VLIO Controller Module* because it allows the data collected in each virtual loop and processed by the VL-SENSOR-D Device to be sent to the Traffic Light Controller.



Data connection: The RJ-45 serial interface is used for communicating data from the Monitoring Set to the VIGIA-VLIO Controller Module.

10. First Access VIGIA-VL Web Interface

After the physical installation of the Monitoring Set and the VIGIA-VLIO Controller Module, the electrical and data connections must be checked. The system can be accessed by Google Chrome browser from version 56 on, with a notebook connected to the respective Monitoring Set or Controller Module. To do so, type the IP address of the device into the navigation bar and provide the factory default user data and password:

IP do VIGIA-VL	192.168.0.1*
User	<i>admin</i>
Password	<i>admin</i>

* Either an IP address compatible with the existing network configuration at the site.

In the Monitoring Suite there is a VL-SENSORr-D image capture and processing device, which has some adjustments that can be made using the VIGIA-VL interface.

First Access VL-SENSOR-D

When connecting the VL-SENSOR-D image capture and processing device to the switch, VIGIA-VL registers it automatically. For cases where automatic registration fails, follow the steps:

- 1) Access the device's web through the default recovery IP: 192.168.0.250;
- 2) Enter the System > Network > Basics menu;
- 3) Change the fields "IP Address", "Subnet Mask", "Default Gateway", "Primary DNS" and "Secondary DNS" according to the user's network;
- 4) Click on the "Save" button;
- 5) After 15 seconds the device will have restarted with the new network settings and can be added manually in the VIGIA-VL interface.

This operation must be repeated on all the cameras that will make up the VIGIA-VL system

11. Care and Maintenance

Some care is needed to protect the equipment, because it reduces the probability of failure and allows for the best product performance.



Product Risks: Using the product presents risks, which are presented in the Handling Risks section.

Firmware Update

Perform the following steps to perform the update:

- 1) Access the Pumatronix website and download the VIGIA-VL update file, which has three software packages (they can be updated individually or all at once, with the process done in the background, after sending the update files).
- 2) Connect an Ethernet cable to the auxiliary computer with Google Chrome browser and to the VIGIA-VLIO Controller Module;

3) Go to System menu > System Maintenance;

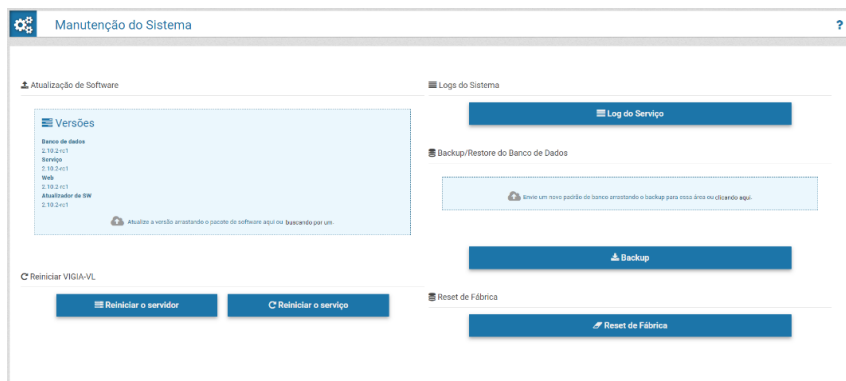

4) Install the 4 update packages (DB, service, Web and SW Updater) by selecting and dragging all files at once to the Versions area, or by clicking on the link to search for a saved file.

The *VLIO board* (intended for interconnection with the traffic light controller) has firmware that can be updated by external software, installed in equipment connected directly to the board. Contact Pumatronix Technical Support for assistance in updating this item.

Preventive Maintenance



Maintenance interval: The maintenance procedures described in this manual have a suggested frequency, however there may be situations in which activities must be performed at shorter time intervals.

Preventive Electrical Maintenance

The items that affect the electrical installations and should be inspected every six months are:

- State of the VLIO Board LEDs;
- Presence of humidity at the installation site of the Control Boards and the VIGIAVLIO Controller Module

Preventive Maintenance of the VL-SENSOR-D Image Capture and Processing Device Fixture

Due to the installation of the VL-SENSOR-D Device in structures close to places with constant traffic flow, the original position defined for the Device can be changed due to the vibration resulting from the passage of large vehicles on the road, or even by accidental collisions that may occur with the equipment.

It is essential that the position initially defined for the VL- SENSORD Device be confirmed periodically, in order to ensure that the presence of vehicles is detected by the virtual loops. This position of the virtual loops can be confirmed using the images produced as a reference by following them through the VIGIA-VL interface. If the loops are out of position, the VL-SENSOR-D device must be repositioned on the support, thus correcting the position of the virtual loops.

Preventive Maintenance of the Protection Tab of the VL-SENSOR-D Image Capture and Processing Device

The VL-SENSOR-D device must provide images that provide identification of the vehicle's presence in the virtual loop. Therefore, the movable flap must be fully extended to block light rays that may fall directly on

the lens and cause reflections in the captured images. Perform a semi-annual inspection of the flap positioning, as it can be displaced due to the shaking resulting from the passage of large vehicles on the road, or even by accidental collisions that may occur with the equipment.

Preventive Maintenance of the VL-SENSOR-D Image Capture and Processing Device Lenses

The VL-SENSOR-D device must provide images that provide identification of the presence of the vehicle in the virtual loop. However, if the outer surface of the lens is dirty, identification can be compromised. To maintain the quality of the images, clean the acrylic lens every six months, or whenever dirt is noticed when following the images displayed through the software interface. To clean the outer surface of the lens effectively, follow these steps:

- 1) Spray water on the acrylic so that it is possible to remove excess dirt adhering to the surface;
- 2) Use a soft, lint-free cloth to remove the dirt, dampened only with water and moving the cloth in one direction only;
- 3) Wipe with a dry cloth after cleaning and do not use force, as this may damage the acrylic.



Acrylic Maintenance: Clean with non-abrasive materials, and when cleaning and drying the lenses, do not use force, as it can damage the acrylic.

12. General Conditions of the Warranty

Pumatronix guarantees the product against any defect in material or manufacturing process for a period of 1 year from the date of issue of the invoice, provided that, at the discretion of its authorized technicians, a defect is found under normal conditions of use.

The replacement of defective parts and the performance of services resulting from this Warranty will only be carried out at the Authorized Technical Assistance of Pumatronix or a third party expressly indicated by it, where the product must be delivered for repair.

This Warranty will only be valid if the product is accompanied by a Maintenance Form duly completed and without erasures and accompanied by an Invoice.

Situations in which the Product Loses the Warranty

- 1) Use of software/hardware not compatible with the Manual's specifications;
- 2) Connection of the product to the electrical network outside the standards established in the product manual and installations that present excessive voltage variation;
- 3) Infiltration of liquids from the opening/closing of the product;
- 4) Damage caused by natural agents (electrical discharge, flooding, sea air, excessive exposure to climatic variations, among other factors) or excessive exposure to heat (beyond the limits established in the Manual);
- 5) Use of the product in environments subject to corrosive gases, with excessive humidity and/or dust;
- 6) Show signs of tampering with security seals;
- 7) Showing signs of opening and modification made by the Customer in product locations not authorized by Pumatronix;
- 8) Damage caused by accidents/falls/vandalism;

- 9) Display tampered and/or removed serial number;
- 10) Damage resulting from the transport and packaging of the product by the Customer in incompatible conditions;
- 11) Misuse and in disagreement with the Instruction Manual Política de Privacidade

13. Privacy Policy

In compliance with the Brazilian General Data Protection Act (LGPD) - Law No. 13.709 of August 14, 2018, this product has programmable functions for capturing and processing images that may violate the LGPD when used in conjunction with other equipment to capture personal data.

The equipment does not collect, use or store personal information, whether sensitive or not, for its operation.

Pumatronix is not responsible for the purposes, use and handling of images captured, whereas control over product information and forms of operation are solely the responsibility of the product user or buyer.





www.pumatronix.com

